





BC360L

Electronic Weighing Indicator
Technical/User Manual

	 WARNING
	<ol style="list-style-type: none">1. This product is precision measure equipment; make sure equipment is properly grounded before use.2. Only authorized person is allowed to debug, test and maintain system.

	CAUTION
Observe precaution for handling electrostatic sensitive Devices.	

	CAUTION
Always remove power and wait at least eight (8) seconds before any connection or disconnection. Regardless of this precaution could result in damage to the equipment and/or body.	

All rights reserved.
No part of this manual may be copied or transmitted in any form or by any means for any purpose without the written permission of SYMC Technology Inc.

Contents

1	ATTENTIONS	1
2	MODEL AND SPECIFICATION	2
2.1	CONFIGURATION	2
2.2	FEATURES	2
2.3	TECHNICAL SPECIFICATION	2
2.4	TEMPERATURE AND HUMIDITY	3
2.5	ENCLOSURE & MOUNTING SIZE	3
3	INSTALLATION AND CONNECTION	4
3.1.	INSTALLATION	4
3.2.	WIRING CONNECTION	4
4	DISPLAY & PANEL	6
4.1	KEYPAD	6
4.2	LED CURSORS	6
4.3	VIEW STATISTIC INFORMATION.	7
4.4	CLEAR TOTAL STATISTICS	7
5	SHORTCUT ENTRY TO SETPOINT EDIT	8
5.1	OVER-UNDER MODE (F2.1=1)	8
5.2	CHECK-WEIGH MODE (F2.1=2)	8
5.3	PRESET POINT MODE (F2.1=3)	9
5.4	FILL MODE (F2.1=4/5).....	10
5.5	TWO-SPEED WEIGH-IN FEED (F2.1=6)	11
5.6	TWO-SPEED WEIGH-OUT FEED (F2.1=7)	11
5.7	PEAK FORCE CAPTURE MODE (F2.1=8).....	12
5.8	DRUM-FILL MODE WITH FILL-GUN(F2.1=9)	13
5.9	OVER-UNDER MODE WITH ZERO RANGE(F2.1=10).....	13
6	SETUP CONFIGURATION	14
	MENU F1 -- SCALE PARAMETERS	14
	MENU F2 -- APPLICATION PARAMETERS	16
	MENU F3 -- PLC INTERFACES	23
	MENU F4 -- SERIAL PORTS.....	23
	MENU F5 -- MAINTENANCE	25
	APPENDIX 1 MODBUS-RTU PROTOCOL (F4.1 = 2, F4.3=2)	26
	APPENDIX 2 CONTINUOUS OUTPUT (F4.1 = 1, F4.3=1)	29
	APPENDIX 3 MT CONTINUOUS OUTPUT (F4.1 = 3, F4.3=3)	30
	APPENDIX 4 PRINT OUTPUT	32

APPENDIX 5 CONTINUOUS OUTPUT 3	33
APPENDIX 6 COMMAND MODE	34
APPENDIX 7 PROMPT OR ERROR MESSAGES	35
APPENDIX 8 PACKING LIST	36

1 Attentions

Thank you for choosing BC360L Electronic Weighing Indicator. For proper application please read this manual carefully before installation.

Check the package be well and make sure the package contents is comply with the packing list.

Check the product model and type is accordance with your order. The product model information is on the label brand above the enclosure.

If there is any parts missed, broken, or model in-conformity in new carton, please prepare the evidence (such as order No., the date of receive goods, product serial No.) and contact our branch office, authorized agency, or service department to deal with.

Ground connection: to ensure the measuring performance and prevent shock hazard, the terminal must be well grounded.

Power supply: This terminal is powered by DC24V.

Environment: BC360L is not an intrinsic safe terminal and can not be used in hazardous area of explosive dust and gas directly.

2 Model and Specification

BC360L weighing controller is designed specially focused on industrial weighing control application. The terminal is equipped with 24-bit Σ - Δ A-D converter, isolated RS232 and RS485 interface, and 16-bit D/A outputs with flexible Volt or Amp outputs. The terminal has panel and water-proof harsh enclosures to fit different mounting surface such as control-box, desk, wall and column mounting. This terminal can be widely used for such as metallurgy, chemical industry, construction material industry, painting, cereal & feed, beverage, and in/out port etc. industrial fields.

2.1 Configuration

Model	P.N	Description
BC360L1	20000263	Panel, 2-in,3 Relays, RS232/RS485, Red LED ,24VDC
BC360L2	20000264	Panel, 2-in,3 Relays, RS232/RS485,4~20mA/0~10v, Red LED ,24VDC

2.2 Features

- * 24 bits high resolution Σ - Δ A-D conversion
- * 1~9 level filter depth
- * 3 N-O relay outputs
- * Isolated RS232 and RS485 serial interface
- * Optional analog output: 4~20mA/ 0~20mA/ 0~5V/ 0~10V
- * Optional PROFIBUS DP interface.
- * 7-digits LED display with 0.56' height
- * Embedded work-flow: check weigh, over-under checking, Setpoint, Gross/Net Filling, Dual-speed feeding, weighing-out, peak-force measure.
- * Standard MODBUS RTU protocol
- * Continuous outputs via RS232 or RS485 for Remote display
- * Cloned display & operation with 2 BC360Ls.

2.3 Technical Specification

- * Load cell: 5.0VDC Excitation with 6 parallel 350 Ω -analog cells.
- * 4-20mA output: load resistance less 500 Ω
- * 0-10v output: load resistance over 200 k Ω
- * Relay Outputs: 1A / 250VAC

- * Load cell sensitivity: $>0.2\mu\text{V/d}$
 - * Linearity: $<0.01\%FS$
 - * Power supply: the terminal has AC and DC series available.
- Power Supply Range: 18~36VDC.

2.4 Temperature and Humidity

Operation temperature: $0^{\circ}\text{C}\sim 40^{\circ}\text{C}$, $<85\%RH$, non-condensation.

Storage temperature: $-20^{\circ}\text{C}\sim 60^{\circ}\text{C}$, $<85\%RH$, non-condensation.

2.5 Enclosure & mounting size

Dimension (Panel, unit: mm): $110\times 62\times 92.5$. Cutout (mm): 46×93

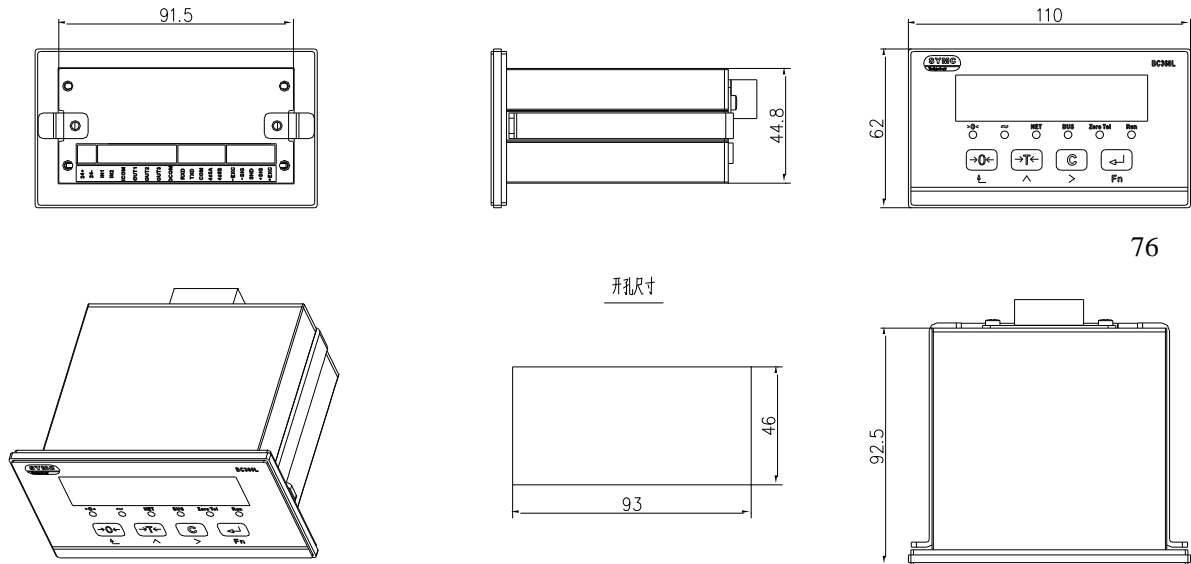

3 Installation and Connection

3.1. Installation

For Panel mount model, the thickness of mounting door should be less than 2mm and box depth should be over 180mm.

3.2. wiring Connection

Backplate connection drawing (Panel)

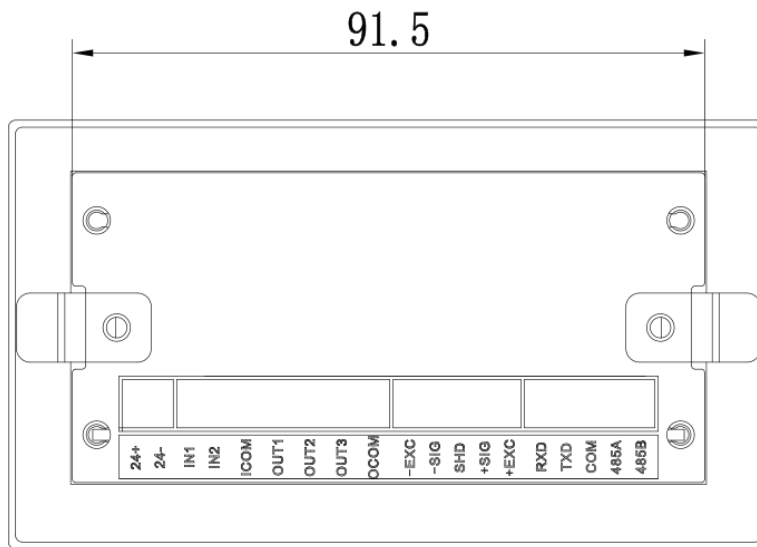

3.2.1. Power connection

For AC model, connect the AC power line with terminal L and N.

For DC model, connect the 24VDC power line with terminal 24+ and 24-.

Whatever the model is AC or DC, the terminal PE must be well grounded.

3.2.2. Load cell interface

Terminal	Description	4 wire
+EXC	positive excitation. short with +SEN if connecting 6-wire cell	red
+SIG	positive signal	green
SHIELD	shield ground	
-SIG	negative signal	white
-EXC	negative excitation. short with -SEN if connecting 6-wire cell	black

3.2.3. Serial Port

The indicator includes 2 isolated serial ports, one is RS232, one RS485.

Pin definition	Description	Function
TXD	RS232 transmit data	Continuous output, print output, command output, MODBUS RTU.
RXD	RS232 receive data	
COM	Common ground	
485A	RS485 T/R +	Same selections with RS232 port.
485B	RS485 T/R -	

3.2.4. Analog output connection

Pin definition	Function	Description
VOUT	0~10v out port	The pluggable terminal can connect voltage or current out port but only one port is active the same time. Customer should configure the output mode by setting menu F3.1 first.
ACOM	Common ground	
IOUT	4~20mA out port	

3.2.5. Discrete IO connection

The indicator has 2 discrete inputs and 3 N-O relay outputs. The input will be active if connect with ICOM. The relay outputs are normally open with OCOM. The operator must be aware of the three relays share one OCOM. Each relay can afford load with 1A@250VAC.

F2.1	Definitions							
Setting	IN2	IN1	ICOM	OUT1	OUT2	OUT3	OCOM	MODE
1, 2	F2.8	F2.9	Input common ground	UNDER	OK	OVER	Output common ground	Over-under/Check-weigh
3	F2.8	F2.9		SPA	SPB	SPC		Preset point mode
4,5	START	PAUSE		END	FAST FEED	SLOW FEED		Gross/Net Fill
6	START	PAUSE		DUMP	FAST FEED	SLOW FEED		Weigh-in feed
7	START	PAUSE		REFILL	FAST FEED	SLOW FEED		Weigh-out feed
8	-	-		UNDER	OK	OVER		Peak force
9	START	PAUSE		FILL-GUN	FAST FEED	SLOW FEED		Drumfilling with fill-gun
10	F2.8	F2.9		ZERO	LO	HI		Over-under with zero range
11	START	CLAMP REQ.		CLAMP OUT	FAST FEED	SLOW FEED		Weigh-in feed with clamp out.





4 Display & Panel

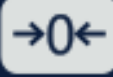

4.1 Keypad

1234567

The BC360L panel includes 4 function keys to accomplish basic operation and setting menu navigation.

Keypad	Definition	Description
	Zero key	Normal: Short press: zero scale. Long press: Clear total batch & weights. Menu: Return;
	Tare key	Normal: Tare/ Clear tare of the scale. Menu : shift the active edit digit right.
	Select key	Normal: Short press: view statistic qty/weight, tare weight. Long press: Short setpoint editing entry. Menu: scroll selection or increase numeric.
	Enter key	Normal: Long press: Enter into setup menu. Menu : Enter, confirm the selection or number.

4.2 Led Cursors

Cursors	Description
>0<	Current display weight is near center of zero.
~	Current weight is in motion.
NET	Current display weight is net weight with non-zero tare weight
BUS	The RS485 comm is active
Zero Tol	The weight is under zero tolerance
Run	The sequence is running

4.3 View statistic information.

Press  key to view available information.

【Tare weight】

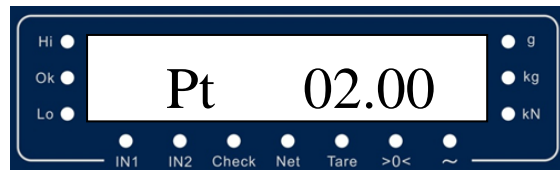

【Total Counts】

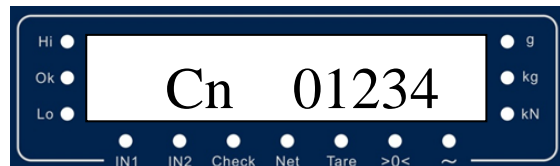

【Total weight】

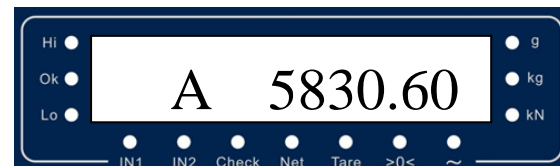

4.4 Clear total statistics

The display will show 【-OF-】 if the total statistics grow over flow. The operator can press and hold $\rightarrow 0 \leftarrow$ zero key to reset the statistics data in this condition.

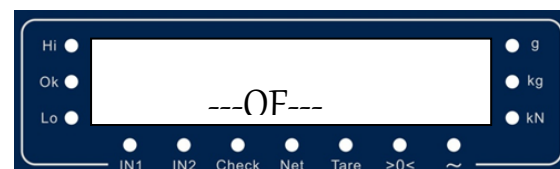

5 Shortcut Entry to Setpoint Edit

Press and hold Select key C entering into Setpoint edit entry if the parameter F2.1 be set as non-zero.

5.1 Over-Under mode (F2.1=1)

The left digit display 'L' meaning current editing parameter is UNDER setpoint.

Press $\rightarrow T \leftarrow$ key to shift the blinking digit right.

Press C key to scroll the numeric up from 0~9cycly.

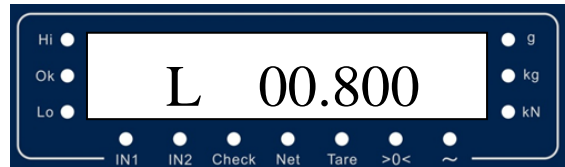

Press $\leftarrow \downarrow$ ENTER key to save paras or press $\rightarrow 0 \leftarrow$ CANCEL key to exit without save.

The left digit display 'H' meaning current editing parameter is OVER setpoint.

Press $\rightarrow T \leftarrow$ key to shift the blinking digit right.

Press C key to scroll the numeric up from 0~9cycly.



Press $\leftarrow \downarrow$ ENTER key to save paras or press $\rightarrow 0 \leftarrow$ CANCEL key to exit without save.

The upper demo paras take effect as below:

Over-under mode (F2.1=1)	Weight < 0.800	0.800 < weight < 2.950	Weight > 2.950
	Relay OUT1 active	Relay OUT2 active	Relay OUT3 active

5.2 Check-weigh mode (F2.1=2)

The left digit display 't' meaning current editing parameter is Target setpoint value.

Press $\rightarrow T \leftarrow$ key to shift the blinking digit right.

Press C key to scroll the numeric up from 0~9 cycly.

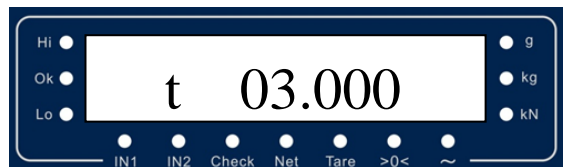

Press $\leftarrow \downarrow$ ENTER key to save paras or press $\rightarrow 0 \leftarrow$ CANCEL key to exit without save.

The left digit display 'P' meaning current editing parameter is Positive tolerance setpoint value.
 Press $\rightarrow T \leftarrow$ key to shift the blinking digit right.
 Press C key to scroll the numeric up from 0~9 cyclicly.

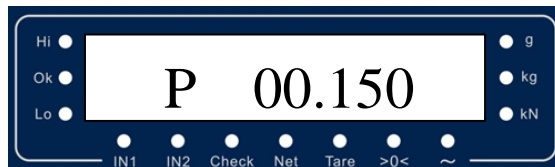

Press $\leftarrow \downarrow$ ENTER key to save paras or press $\rightarrow 0 \leftarrow$ CANCEL key to exit without save.

The left digit display 'n' meaning current editing parameter is Negative tolerance setpoint value.
 Press $\rightarrow T \leftarrow$ key to shift the blinking digit right.
 Press C key to scroll the numeric up from 0~9 cyclicly.

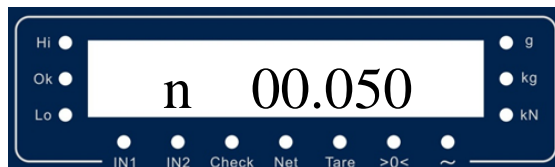

Press $\leftarrow \downarrow$ ENTER key to save paras or press $\rightarrow 0 \leftarrow$ CANCEL key to exit without save.

The upper demo paras take effect as below:

Weight < 2.950	2.950 < Weight < 3.150	Weight > 3.150
Relay OUT1 Active	Relay OUT2 Active	Relay OUT3 Active

※ Note: all three relays will stay inactive if the display weight is under the zero range (set by F2.2).

5.3 Preset point mode (F2.1=3)

Set the preset point 1 (SPA)

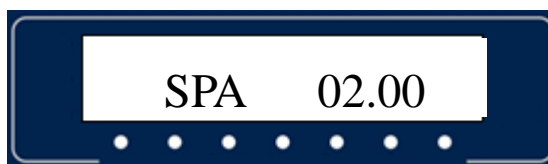

Set the preset point 2 (SPB)

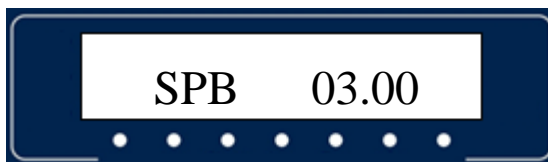

Set the preset point 3 (SPC)



5.4 Fill mode (F2.1=4/5)

F2.1 = 4: Net Fill

F2.1 = 5: Gross Fill

Set the container's tare weight low range.

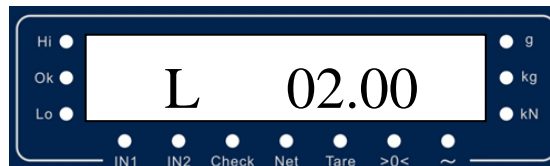

Set the container's tare weight high range.

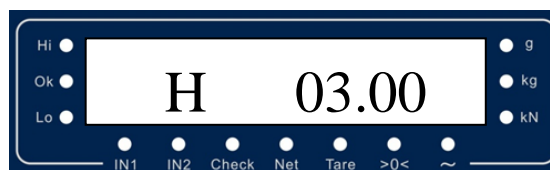

Set the filling target weight.

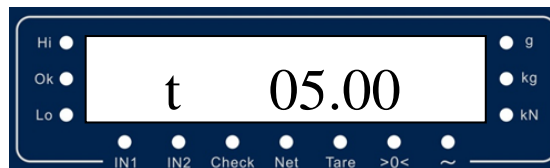

Set the coarse feed preact weight. In this example, the filling target is 5.00kg, the coarse feed setpoint is 1.00kg. That means the coarse feed output status will change from active to inactive while the filling weight over $(5.00 - 1.00 = 4.00)$ kg.



Set the spill weight. In this example, the filling target is 5.00kg, the spill setpoint is 0.30kg. That means the fine feed output status will change from active to inactive while the filling weight over $(5.00 - 0.30 = 4.70)$ kg.

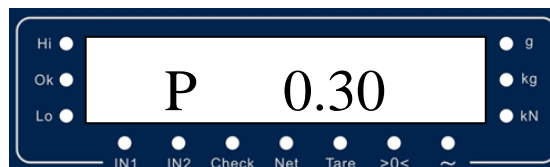

5.5 two-speed weigh-in feed (F2.1=6)

Set empty range of the scale.the terminal complete a weigh-in feed cycle if the weight is discharged under this empty range value.

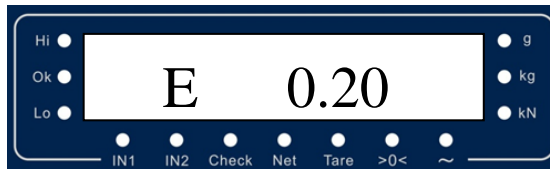

Set the target weight.

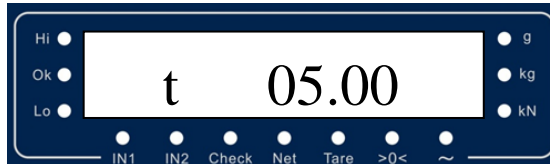

Set the coarse feed preact weight. In this example, the filling target is 5.00kg, the coarse feed setpoint is 1.00kg. That means the coarse feed output status will change from active to inactive while the filling weight over $(5.00 - 1.00 = 4.00)$ kg.

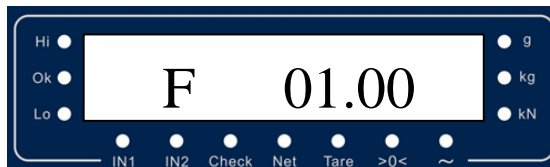

Set the spill weight. In this example, the filling target is 5.00kg, the spill setpoint is 0.30kg. That means the fine feed output status will change from active to inactive while the filling weight over $(5.00 - 0.30 = 4.70)$ kg.

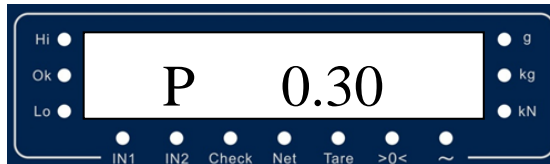

5.6 two-speed weigh-out feed (F2.1=7)

Set the refill trigger value. if the weight is less than this value, the sequence first trigger a refill output before weigh-out feeding.

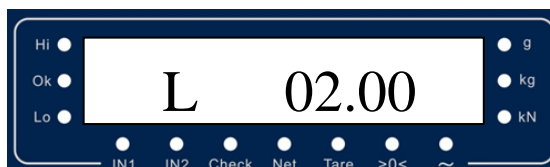

Set the refill sequence stop value. the terminal set the refill output inactive if the refilling weight be over this value.

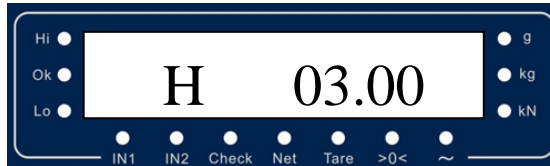

Set the target weight value.

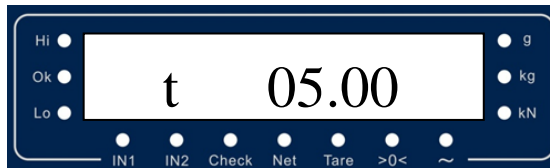

Set coarse feed preact weight.

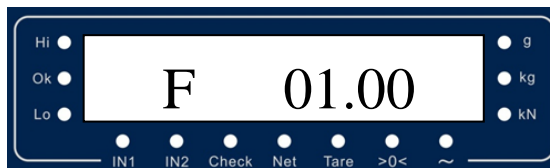

Set spill weight.

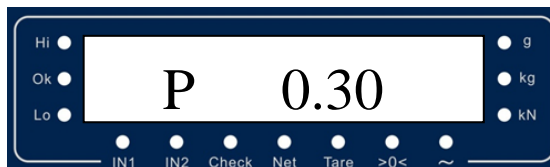

5.7 Peak force capture mode (F2.1=8)

Set empty range of the scale.

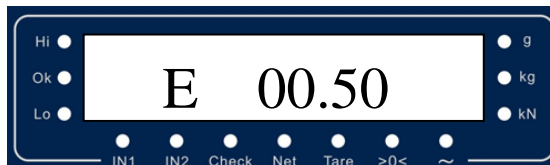

Set Peak force lower range.

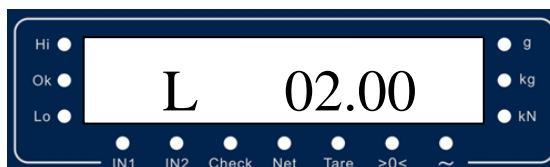

Set peak force High range.

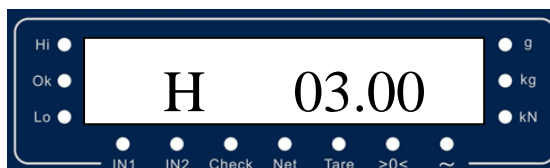

5.8 Drum-fill mode with fill-gun(F2.1=9)

The parameters setting in this work mode is same with the mode if F2.1 = 4, 5.

5.9 Over-Under mode with zero range(F2.1=10)

Set empty range of the scale.

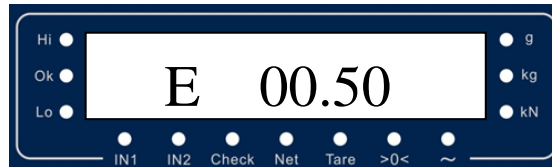

Set Peak force lower range.



Set peak force High range.

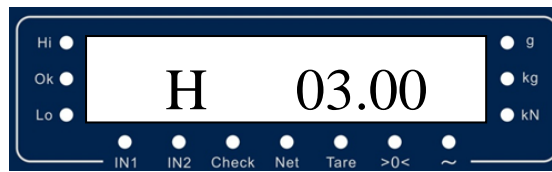

5.10 Net Feeding with Clamp-bag mode(F2.1=11)

Set the target weight value.

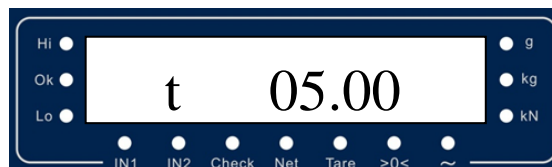

Set coarse feed preact weight.

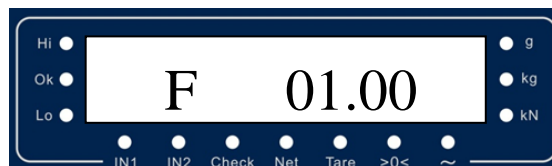

Set spill weight.

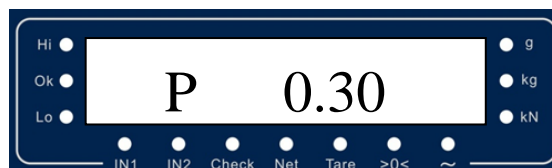

6 Setup Configuration

Note:

To protect the metrological parameters from destroyed by mistake, there is a password entry validation to access the scale capacity, increments, calibration and other sensitive paras.

The fixed password is “2000” (“8837” earlier than REV1.13). if you are trying to enter F1.1 the password entry will show as below. Do not enter code or incorrect code will cause the terminal skip to next branch menu F2.

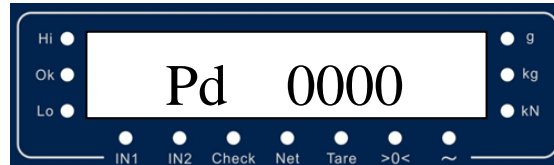

Press and hold ENTER key  till {F1 } displayed.

In setup menu, press SELECT key  to shift next branch menu F2. Press ZERO key $\rightarrow 0 \leftarrow$ to return to upper level.

Menu F1 -- Scale parameters

F1.1 Scale Capacity ----- Default: 10

Range:1 ~ 100000.

the entry value is limited equal or less than 60000 if configure this value via MODBUS.

F1.2 Decimal point ----- Default: 3

Display Unit is [kg] Range: 0 ~ 4

Display Unit is [g] Range: 0 ~ 1

F1.3 increments factor ----- Default: 1

1 / 2 / 5 / 10 / 20 / 50 optional

F1.4 display unit ----- Default: kg

0: kg 1: kN (the decimal point is fixed as 3 in this unit) 2: g

F1.5 Gravity ----- Default: 9.7458

Range: 9.0000 ~ 9.9999

F1.6 Zero Calibration

{E_SCAL } : prompts to empty scale before calibration.

Following the prompts to move loads on the scale then press ENTER key to start sample the empty scale signal.during the calibration, there maybe display any prompt messages. For detailed explanation, please refer to sheet <prompts table> in the end of this manual.

F1.7 Load Calibration

Step 1.

[dot 2] In this prompt to select 2-point or 3-point calibration.

[dot 2] 2-point capacity calibration.

[dot 3] 3-point linearity calibration.

Step 2.

[LOAD] prompt to add calibration weight WT.

Place weight on the scale and wait till the scale be stable. Press ENTER key entering into load weight input dialog. Input corresponding weight value then press ENTER key to calibrate the added load. In calibrating dialog a number will count down from 10~0.

Step 3. (This step shows only selecting 3-point linearity calibration.)

[LOAD2] prompt to add second load weight WT2.

Place weight on the scale and wait till the scale be stable. Press ENTER key entering into load weight input dialog. Input corresponding weight value then press ENTER key to calibrate the added load. In calibrating dialog a number will count down from 10~0.

Note: The calibrating unit is fix as kg.

The add load weight should not less than 1% of Capacity (F1.1).

F1.8 filter depth ----- Default:1

Range:1 ~ 9. the bigger the number, the stable the weight.

F1.9 Motion Range ----- Default:OFF.

OFF(no motion detect) / 1d / 2d / 3d / 4d / 5d

F1.10 Over load range ----- Default: 9d

9d / 5 / 10 / 20 (±9d / 5%Capacity / 10%Capacity / 20%Capacity)

F1.11 Power-up Zero Range ----- Default: OFF

OFF / 5 / 10 / 20 (disable / 5%Capacity / 10%Capacity / 20%Capacity)

F1.12 Keypad zero range ----- Default: 5

OFF / 5 / 10 / 20 (Disable / 5%Capacity / 10%Capacity / 20%Capacity)

F1.13 Auto Zero Maintain Range ----- Default: OFF

OFF(disable) / 1d / 2d / 3d / 4d / 5d

Menu F2 -- Application parameters.

F2.1 work mode ----- Default: 0

0: General application

1: Over-Under Mode

I/O Definition:

IN2:F2.8. IN1: F2.9

OUT1: Under; OUT2:Ok; OUT3:Over.

Setpoint Entry: Under range(F2.3), Over Range(F2.4). Or press and hold SELECT key

 to set the Under or Over range value.

2: Check-weigh mode

I/O Definition:

IN2:F2.8. IN1: F2.9

OUT1: Under; OUT2:Ok; OUT3:Over.

Setpoint Entry:

F2.2: Empty Range.

F2.5: Target.

F2.6: Positive tolerance.

F2.7: Negative tolerance.

The operator also can access and edit the setpoints by press and hold SELECT key

 in normal display mode.

3: Preset point mode

I/O Definition:

IN2:F2.8. IN1: F2.9

OUT1: $WT \geq SPA$; OUT2: $WT \geq SPB$; OUT3: $WT \geq SPC$.

Setpoint Entry:

F2.3: SPA Weight.

F2.5: SPB Weight.

F2.6: SPC Weight.

Work Flow Description:

Assume that the current display weight is $WT\{SPA < SPB < SPC\}$

if $WT < SPA$: OUT1 is off; OUT2 is off; OUT3 is off;

if $SPA \leq WT < SPB$: OUT1 is on; OUT2 is off; OUT3 is off;

if $SPB \leq WT < SPC$: OUT1 is on; OUT2 is on; OUT3 is off;

if $WT \geq SPC$: OUT1 is on; OUT2 is on; OUT3 is on;

4: Net Filling mode

I/O Definition:

IN2:Start Filling (Level active). IN1: Pause Filling procedure.

OUT1: Fill End\ Push the Container\ Discharge. OUT2: Coarse Filling. OUT3:

Fine Filling.

Setpoint Entry:

F2.3: Container Tare Under Range.

F2.4: Container Tare Upper Range.

F2.5: Target. This value is net filling target weight.

F2.10: Fast Feed Preact setpoint.

F2.11: sPill setpoint.

F2.12: Compare-Inhabit Time

F2.13: Stable Time

The operator also can access and edit the setpoints [L],[H] [T],[F],[P] by press and hold SELECT key  in normal display mode.

Work Flow Description:

Step1: Place container on the scale

Step2: if the container tare weight WT fulfill $\{L < WT < H\}$, press IN2 switch to ON to tare the container and start filling. When begin filling the outputs OUT2, OUT3 turn to active.

Step3: The output OUT2 will be inactive and turn to slow feeding if current net weight $W_{net} \geq \text{Target (F2.5) - Fast Feed (F2.10)}$.

Step4: The output OUT3 will be inactive to end filling if current net weight $W_{net} \geq \text{Target (F2.5) - sPill Preact (F2.11)}$.

Step5: the terminal waits the weight be stable then sums up the net result.

Step6: the output OUT1 be active to push the container or discharge till the displayed net weight $W_{net} \leq -(\text{Container tare weight})/2$.

Step7: clear tare weight and end the filling procedure.

5: Gross Filling mode

I/O Definition:

IN2:Start Filling (Level active). IN1: Pause Filling procedure.

OUT1: Fill End\ Push the Container\ Discharge. OUT2: Coarse Filling. OUT3: Fine Filling.

Setpoint Entry:

F2.3: Container Tare Under Range.

F2.4: Container Tare Upper Range.

F2.5: Target. This value is gross target include container tare weight.

F2.10: Fast Feed Preact setpoint.

F2.11: sPill setpoint.

F2.12: Compare-Inhabit Time

F2.13: Stable Time

The operator also can access and edit the setpoints [L],[H] [T],[F],[P] by press and hold SELECT key  in normal display mode.

Work Flow Description:

Step1: Place container on the scale

Step2: if the container tare weight WT fulfill $\{L < WT < H\}$, press IN2 switch to ON to start filling without taring the scale. When begin filling the outputs OUT2, OUT3 turn

to active.

Step3: The output OUT2 will be inactive and turn to slow feeding if current weight $Wt \geq \text{Target (F2.5) - Fast Feed (F2.10)}$.

Step4: The output OUT3 will be inactive to end filling if current displayed weight $Wt \geq \text{Target (F2.5) - sPill Preact (F2.11)}$.

Step5: the terminal waits the weight be stable then sums up the gross weight.

Step6: the output OUT1 be active to push the container or discharge till the displayed weight $Wt \leq (\text{Container tare weight})/2$.

Step7: The filling procedure end.

6: Weigh-in Feed Mode (1 material)

I/O Definition:

IN2:Start Feeding (Pulse active). IN1: Stop Feeding(Pulse active).

OUT1: Feed over\ Discharge. OUT2: Coarse Feeding. OUT3: Fine Feeding.

Setpoint Entry:

F2.2: Empty Range.

F2.5: Target.

F2.10: Fast Feed Preact setpoint.

F2.11: sPill setpoint.

F2.12: Compare-Inhabit Time

F2.13: Stable Time

The operator also can access and edit the setpoints [E],[T],[F],[P] by press and hold SELECT key  in normal display mode.

Work Flow Description:

Step1: Press **IN2** switch to ON to start feeding. When begin feeding the outputs OUT2, OUT3 turn to active.

Step2: The output OUT2 will be inactive and turn to slow feeding if current weight $Wt \geq \text{Target (F2.5) - Fast Feed (F2.10)}$.

Step3: The output OUT3 will be inactive to end feeding if current displayed weight $Wt \geq \text{Target (F2.5) - sPill Preact (F2.11)}$.

Step4: the terminal waits the weight be stable then sums up the gross weight.

Step5: the output OUT1 be active to alarm the feeding is completed or discharge till the displayed weight $Wt \leq \text{Empty Range}$.

Step6: Clear tare weight and end the feeding procedure.

7: Weigh-out Feed Mode (1 material)

I/O Definition:

IN2:Start Feeding (Pulse active). IN1: Stop feeding(Pulse active).

OUT1: Refill. OUT2: Coarse Feeding. OUT3: Fine Feeding.

Setpoint Entry:

F2.4: The Upper Limit of the hopper scale.

F2.5: Target.

F2.10: Fast Feed Preact setpoint.

F2.11: sPill setpoint.

F2.12: Compare-Inhabit Time

F2.13: Stable Time

The operator also can access and edit the setpoints [H],[T],[F],[P] by press and hold SELECT key  in normal display mode.

Work Flow Description:

Step1: Press IN2 switch to ON to start feeding procedure.

Step2: terminal will turn on Refill output OUT1 if the current weight < Target weight.

Step3: Refill the weight to reach Upper Limit weight (F2.4) then turn off OUT1.

Step4: Tare the weight if stable and turn on outputs OUT2, OUT3 to start fast feeding.

Step5: The output OUT2 will be inactive and turn to slow feeding if current weight $Wt \leq -(\text{Target (F2.5)} - \text{Fast Feed (F2.10)})$.

Step6: The output OUT3 will be inactive to end feeding if current displayed weight $Wt \leq -(\text{Target (F2.5)} - \text{sPill Preact (F2.11)})$.

Step7: the terminal waits the weight be stable then sums up the net feeding weight.

Step8: Clear tare weight and end the feeding procedure.

8: Peak Force Mode

I/O Definition:

IN1: N/A. IN2: N/A.

OUT1: Lower Range. OUT2: Ok. OUT3: Higher Range.

Setpoint Entry:

F2.2: Empty Range.

F2.3: Lower Range.

F2.4: Higher Range.

F2.13: Peak Force Hold Time

The operator also can access and edit the setpoints [E],[L],[H] by press and hold SELECT key  in normal display mode.

Work Flow Description:

Name the current displayed weight as Wt.

Step1: [Climbing stage] if $Wt < \text{Empty Range (F2.2)}$, the terminal do not record reading Peak force value and the outputs keep inactive.

Step2: [Sample stage] if the weight climb over to fulfill $Wt > \text{Empty Range (F2.2)}$, the terminal begin record reading Peak force value but the outputs still keep inactive.

Step3: [Records Sorting stage] if the weight drop under Empty Range (F2.2) again, the terminal calculate the maximum peak force record and freeze the display at peak force value then output alarm according to setpoint value:

Peak force < [L] Lower Range (F2.3), OUT1=ON, OUT2=OFF, OUT3 = OFF.

Peak force > [H] Higher Range (F2.4), OUT1=OFF, OUT2=OFF, OUT3= ON.

Peak force between [L] and [H] range, OUT1=OFF, OUT2=ON, OUT3= OFF.

Step4: [End Stage] the display and outputs holding time (F2.13) expired, the display return to normal display mode and all output turn to OFF status. A peak force

sampling procedure ends.

9: Net Filling with Fill-Gun mode

I/O Definition:

IN2:Start Filling (Pulse active). IN1: Kill Filling procedure(Pulse active).

OUT1: Fill Gun Up/Don. OUT2: Coarse Filling. OUT3: Fine Filling.

Setpoint Entry:

F2.3: Container Tare Under Range.

F2.4: Container Tare Upper Range.

F2.5: Target. This value is net filling target weight.

F2.10: Fast Feed Preact setpoint.

F2.11: sPill setpoint.

F2.12: Compare-Inhabit Time

F2.13: Stable Time

F2.14: Fill-gun Drop/Lift Time

F2.15: Bucket Impacting Weight

F2.16: Drum-filling mode.

The operator also can access and edit the setpoints [L],[H] [T],[F],[P] by press and hold SELECT key  in normal display mode.

Work Flow Description:

Name the current displayed weight as WT.

Step1: Place container on the scale

Step2: if the container tare weight WT fulfill $\{L < WT < H\}$, press **IN2** switch to ON to start the filling procedure. The output OUT1 turn on for (F2.14) time to drop the fillgun on position. During the dropping period the fill-gun will rise immediately if terminal detect the weight be over the bucket-impacting weight value (F2.15). else the terminal will tare the container and start filling. When begin filling the outputs OUT2, OUT3 turn to active.

Step3: The output OUT2 will be inactive and turn to slow feeding if current net weight $W_{net} \geq \text{Target (F2.5) - Fast Feed (F2.10)}$.

Step4: The output OUT3 will be inactive to end filling if current net weight $W_{net} \geq \text{Target (F2.5) - sPill Preact (F2.11)}$.

Step5: the terminal waits the weight be stable then sums up the net result.

Step6: the output OUT1 turn OFF to rise the fillgun for (F2.14) time.

Step7: wait till the displayed net weight $W_{net} \leq -(\text{Container tare weight})/2$.

Step8: clear tare weight and end the filling procedure.

10: Over-Under Mode with zero range

I/O Definition:

IN2:F2.8. IN1: F2.9

OUT1: Zero; OUT2: Under; OUT3:Over.

Setpoint Entry: Zero Range(F2.2), Under range(F2.3), Over Range(F2.4). Or press

and hold SELECT key  to set the Under or Over range value.

Work Flow Description:

Name the current displayed weight as WT.

WT < [E]: **OUT1: Active, OUT2: Active**, OUT3: Inactive.

[E] < WT < [L]: OUT1: Inactive, **OUT2: Active**, OUT3: Inactive.

[L] <= WT <= [H]: OUT1: Inactive, OUT2: Inactive, OUT3: Inactive.

WT > [H]: OUT1: Inactive, OUT2: Inactive, **OUT3: Active**.

11: Net Feeding with Clamp-bag mode

I/O Definition:

IN2:Start Feeding (Level active). IN1: Clamp bag Request(Pulse active).

OUT1: Clamp out. OUT2: Coarse Feeding. OUT3: Fine Feeding.

Setpoint Entry:

F2.5: Target. This value is net feeding target weight.

F2.10: Fast Feed Preact setpoint.

F2.11: sPill setpoint.

F2.12: Compare-Inhabit Time

F2.13: Stable Time

The operator also can access and edit the setpoints [T],[F],[P] by press and hold

SELECT key  in normal display mode.

Work Flow Description:

Clamp action description: Once **IN1** pulse input be active, the OUT1(Clamp out) will be set ON if original in OFF status or be set OFF in verse disregarding the **IN2** status unless OUT3 (Fine feed) is active.

Name the current displayed weight as WT.

Step1: switch **IN2** at ON position.

Step2: press button **IN1** to Clamp bag.

Step3: wait stable time til the scale be stable then tare the empty bag.

Step4: OUT2,OUT3 turn to active to start feeding.

Step5: The output OUT2 will be inactive and turn to slow feeding if current net weight $W_{net} \geq \text{Target (F2.5) - Fast Feed (F2.10)}$.

Step6: The output OUT3 will be inactive to end feeding if current net weight $W_{net} \geq \text{Target (F2.5) - sPill Preact (F2.11)}$.

Step7: the terminal waits the weight be stable then sums up the net result.

Step8: the output OUT1 turns OFF to loose bag.

Step9: clear tare weight and end the feeding procedure.

F2.2 Empty Scale Range(E) ----- Default: 1.000

Input range: 0 ~ CAP

F2.3 Lower Limit Range(L) ----- Default: 2.000

Input range: 0 ~ CAP

F2.4 Upper Limit Range(H) ----- Default: 3.000

Input Range: Low ~ High

- F2.5 Target weight(T) ----- Default: 2.000
Input range: 0 ~ CAP
- F2.6 Positive Tolerance(P) ----- Default: 0.100
Input range: 0 ~ CAP
- F2.7 Negative Tolerance(N) ----- Default: 0.100
Input range: 0 ~ CAP
- F2.8 IN1 Definition ----- Default: 0
0: Zero
1: Tare
2: Clear tare
3:Print
- F2.9 IN2 Definition ----- Default: 0
0: Zero
1: Tare
2: Clear tare
3:Print
- F2.10 Fast Feed weight(F) ----- Default: 0.500
Input Range: 0 ~ Target
- F2.11 Spill Preact weight(P) ----- Default: 0.010
Input Range: 0 ~ Fine
- F2.12 Compare-Inhabit Time ----- Default: 1.0
Input Range: 0.0 ~ 9.9 Seconds
- F2.13 Stable Wait Time ----- Default: 2.0
Input Range: 0.0 ~ 9.9 Seconds
- F2.14 Fillgun Drop/Lifting Time ----- Default: 5.0
Input Range: 0.0 ~ 9.9 Seconds
- F2.15 Bucket Impact Weight ----- Default: 1.000
Input Range: 0 ~ CAP/5
- F2.16 Mode 9 Net/ Gross Selection ----- Default: 0
0: Net Filling
1: Gross Filling

Menu F3 -- PLC interfaces

F3.1 Analog Output Channel ----- Default: 2

F3.1 = 0, Voltage output, Range: 0~5V.

F3.1 = 1, Voltage output, Range: 0~10V.

F3.1 = 2, Current output, Range 4~20mA.

F3.2 Analog Zero Calibration ----- Default: 10920

Connect the corresponding output port with multimeter or analog V/A input of PLC.

Modify the analog zero point counts to adjust analog out value till the reading output value be 0 V/mA or 4mA.

F3.3 Analog Span Calibration ----- Default: 59135

Same with F3.2 operation steps.

When calibrating the analog span output the operate needn't add load on the scale.

F3.4 Profibus DP node address ---- Default: 2

Address range: 1~99.

F3.5 Zero key and Tare key Operate ---- Default: 2

0: Function valid in this end, invalid in remote cloned one.

1: Function invalid in this end, valid in remote cloned one.

2: Function valid in both ends.

Menu F4 -- Serial ports

F4.1 COM1 (RS232) output format ----- Default: 2

0: N/A

1: Continuous output.

2: MODBUS-RTU

3: MT Continuous output.

4: Print output

5: Continuous output model 3

6: Command model

F4.2 COM1 (RS232) Data bit ----- Default: 0 (8_N_1)

8_N_1 / 7_O_1(7 databit, Odd, 1 Stop bit) /

7_E_1 / 8_O_1(8 databit, Odd, 1 Stop bit) / 8_E_1

F4.3 COM2 (RS485) output format ----- Default: 2

- 0: N/A
- 1: Continuous output.
- 2: MODBUS-RTU
- 3: MT Continuous output.
- 4: Print output
- 5: Continuous output model 3
- 6: Command model

F4.4 COM2 (RS485) Data bit ----- Default: 0 (8_N_1)

8_N_1 / 7_O_1(7 databit, Odd, 1 Stop bit) /

7_E_1 / 8_O_1(8 databit, Odd, 1 Stop bit) / 8_E_1

F4.5 Baud Rate ----- Default: 3

1200, 2400, 4800, 9600, 19200, 38400, 57600, 115200.

Note: the two serial ports share the same baud rate.

F4.6 RS232 Node Address ----- Default: 1

Address Range: 1 ~ 99.

F4.7 RS485 Node Address ----- Default: 1

Address Range: 1 ~ 99.

F4.8 Printout Language ----- Default: 0

0:English 1:Chinese

F4.9 Printout Format ----- Default: 0

0:Narrow Row 1:Wide Row

F4.10 Lines of A New Page For Wide Row ----- Default: 40

Lines Range: 2~200

F4.11 Set output times per second for Continuous output model 3 ----- Default: 8

9600 baud rate and above can be set to 4, 8, 16, 20 times/second

4800 baud rate and below can be set to 4, 8 times/second

Menu F5 -- Maintenance

F5.1 Load default parameters

0: skip this operation.

1: execute the operation.

F5.2 Test Display

Press ENTER key to test display. The display will display from “000000” ~ “999999”. watching the display to make sure if there is any segment is burned.

F5.3 Test Input

Press ENTER to let the display show the two inputs status. If the input port status don't change when connect or disconnect the input with ICOM, that port probably be broken.

F5.4 Test Output

In the output test window, press SELECT key to scroll between OUT1 ~ OUT4. Press ENTER key to set the output port ON or OFF.

F5.5 View and Modify calibration parameters

Pd xxxx: Input password. The mismatched password will be denied.

Axxxxxx: Zero point calibration counts.

dxxxxxx: loaded weight point calibration counts.

Exxxxxx: Loaded weight value.

The calibrating data can be view or modified if needed. The operator is suggested to write down the calibration data for reference.

F5.6 Cal-Free operation

Pd xxxx: input access password.

Cxxxxxx: input the total loadcell capacity. E.g. the terminal connect 4 load cells and each load cell's capacity is 100kg. The operator should input the total capacity $100\text{kg} * 4 = 400\text{kg}$.

n 2.000: input the load cell's sensitivity.

【E-SCAL】 : Calibrating empty scale.

F5.7 Easy-to-use calibration

Pd xxxx: Input access password.

E 05.000: Input the estimated load weight.

[L 0Ad]: Prompt to add load weight on the scale.

L 01.000: Input added weight value.

The easy-to-use calibration completed.

Appendix 1 MODBUS-RTU Protocol (F4.1 = 2, F4.3=2)

BC360L supports standard MODBUS-RTU Master-slave network communication protocol. In the network the terminal act as slave node and can be accessed by '03H', '06H' command code.

BC360L node address range can set between 1~99. When using RS485 network, please make sure the indicator address is unique.

Note:

1. Please do not install or use end resistance in the middle node of the network, otherwise the further indicator will be inaccessible.
2. It is recommended to use shield twisted pair-wire and make sure the shield cable connect to earth at the host end.
3. If select MODBUS RTU protocol in COM1 or COM2, the operator must make sure the corresponding serial port data bit be 8.

MODBUS Data-mapping table

Address	Description(Read Only: '03H'command)	
40001	The number of divisions of display weight(-32767 ~ +32767) Note: the actual weight value can be get by this unit reading multiply with increments (F1.3) / 10 ^x , where x is set by F1.2.	
40002	Display weight(floating data)	
40003		
40004	Bit0	1 = Net weight, 0 = Gross weight
	Bit1	1 = be in Motion, 0 = be Stable
	Bit2	1 = weight over capacity, 0 = normal
	Bit3	1 = power up zero failed
	Bit4	1 = OUT1 be active
	Bit5	1 = OUT2 be active
	Bit6	1 = OUT3 be active
	Bit7	1 = IN1 be active
	Bit8	1 = IN2 be active
	Bit9	1 = the total quantity/weights overflow.
Bit10	1 = be filling or feeding	
40036	Displays the final result values at the end of the process except for application mode 0, 1, 2, and 10	

Address	Description (Read/ Write)
40005	Scale capacity:(1~60000) If the capacity is over 60000 the operator can set capacity from the panel.
40006	Decimal point: 0: no Decimal Point; 1: one dp; 2: two dp; 3: three dp; 4: four dp.
40007	Increments factor(1,2,5,10,20,50)

40008	Filter depth(1~9), the bigger number get more stable weight
40009	Motion detect range 0: do not detect motion status. 1 ~ 5: 1 ~ 5d
40010	Overload display range. If the display weight over capacity for this range the terminal will prompt warning message. 0: -9d ~ Capacity - 9d。 1: -Capacity*5% ~Capacity*105%。 2: -Capacity*10% ~Capacity*110%。 3: -Capacity*20% ~Capacity*120%。
40011	Power-up Zero Range. 0: disable power up zero. 1: -Capacity*5% ~ Capacity*105%。 2: -Capacity*10% ~ Capacity*110%。 3: -Capacity*20% ~ Capacity*120%。
40012	Key-pad Zero range 0: disable zero scale by pressing keypad. 1: -Capacity*5% ~ Capacity*105%。 2: -Capacity*10% ~ Capacity*110%。 3: -Capacity*20% ~ Capacity*120%。
40013	Auto Zero Maintain Range 0: disable AZM。 1 ~ 5: 1 ~ 5d
40014	Application mode(0~9) 0: Normal operation 1: Over-Under mode 2: Check-weigh mode 3: Setpoint 4: Net Fill mode 5: Gross Fill mode 6: Weigh-in Feeding 7: Weigh-out mode 8: Peak-Force Holding 9: Drum-Fill with Fill-Gun
40015	Empty Scale Range(0 ~ Capacity / 5)
40016	Lower Limit Range (0~ Capacity)
40017	Higher Limit Range (0~ Capacity)
40018	Target weight (0~ Capacity)
40019	Positive tolerance (0~ Capacity)
40020	Negative tolerance (0~ Capacity)
40021	Calibration status. 1: Zero calibration success. 2: Load calibration success. 3: Too small input weight value. 4: Too big input weight value. 5: Too small add load on span calibration.

Address		Description(Write Only: '06H' command)
40022		<p>Scale Calibration.</p> <p>Zero calibration: Unload the scale to empty and wait for the scale be stable then write 0 to this unit.</p> <p>Span calibration: add load on the scale and wait the scale be stable then write the load weight value into this unit. Be sure the writing value WT should fulfill $\text{Capacity} * 1\% \leq \text{WT} \leq \text{Capacity}$.</p> <p>The calibration result can be readout from 40021.</p>
40023	Bit0	1 = Zero
	Bit1	1 = Tare
	Bit2	1 = Clear tare
	Bit3	1 = Start filling/feeding
	Bit4	1 = Stop/Pause filling
	Bit5	1 = Enter analog calibration mode
	Bit6	1 = Exit analog calibration mode
	Bit7~Bit15	Reserved

Address	Description (Read/ Write)
40024	Fast feed Preact (F2.10). input range: 0 ~ Target
40025	sPill value (F2.11). input range: 0 ~ Fast
40026	Compare-Inhabit-Time(F2.12). input range: 0 ~ 99(100ms)
40027	Stable Time(F2.13). input range: 0 ~ 99(100ms)
40028	Display unit(F1.4): 0-kg, 1-kN
40029	Fill-gun Drop/Lift Time(F2.14). input range: 0 ~ 99(100ms)
40030	Bucket Impact Weight(F2.15). input range: 0 ~ Capacity / 5
40031	Mode 9 N/G Selection(F2.16): 0-Net, 1-Gross
40032	COM1:RS232 port address: 1~99
40033	COM2:RS485 port address: 1~99
40034	Analog zero calibration
40035	Analog span calibration

Appendix 2 Continuous Output (F4.1 = 1, F4.3=1)

In this protocol, the serial port format is fixed as 8 data bit, no parity, 1stop bit, but baud rate is changeable.

The output data frame is composed by 10-byte ASCII characters starting with '='(3dh) and ending with control character CR(0dh), LF(0ah). the transferred data is coincident with the display weight. The data frame is explained as below.

Start	Sign	Weight						End	
=	0/-	MSB					LSB	0D	0A

E.g. the terminal display weight “-1234.5”. the serial port will transfer string as “= -1234.5”.

format	Start	Sign	Weight						End	
character	=	-	1	2	3	4	.	5	CR	LF
Hexadecimal	3d	2d	31	32	33	34	2e	35	0d	0a

Appendix 3 MT Continuous Output (F4.1 = 3, F4.3=3)

This protocol is compatible with TOLEDO continuous output format and can be connected with Remote Display which include TOLEDO continuous output protocol.

The output data frame is composed by 18-byte ASCII characters starting with control character STX (02h) and ending with control character CR(0dh) and/or checksum byte. the transferred data is coincident with the display weight. The data frame is explained as below.

18-byte data frame explanation:

Data Frame																	
ST	A	B	C	X	X	X	X	X	X	X	X	X	X	X	X	C	CK
X																R	S
1	2		3						4						5	6	

1. <STX> ASCII start character(02H)
2. Status byte A, B, C
3. Display weight (Net or Gross), 6 digits without decimal.
4. Tare weight, 6 digits without decimal.
5. <CR> ASCII control character (ODH)
6. <CKS> checksum

Status bytes: A, B,C.

Status byte A			
Bit 0	Bit 1	Bit 2	Decimal Point
0	1	0	XXXXXX
1	1	0	XXXXX.X
0	0	1	XXXX.XX
1	0	1	XXX.XXX
0	1	1	XX.XXXX
Bit 3	Fixed 0		
Bit 4	Fixed 1		
Bit 5	Fixed 0		
Bit 6	Fixed 1		
Bit 7	Fixed 0		
Status byte B			

Bits	Definition
Bit 0	Gross Wt = 0, Net Wt = 1
Bit 1	Sign: Positive = 0, Negative = 1
Bit 2	Over capacity/(Under zero) = 1
Bit 3	Stable = 0, Motion = 1
Bit 4	Fixed 1
Bit 5	Fixed 1
Bit 6	Fixed 0
Bit 7	Fixed 0
Status byte C	
Bits	Definition
Bit 0	Fixed 0
Bit 1	Fixed 0
Bit 2	Fixed 0
Bit 3	Fixed 0
Bit 4	Fixed 1
Bit 5	Fixed 1
Bit 6	Fixed 0
Bit 7	Fixed 0

Appendix 4 Print Output

In this communication format, the following format data is output from the serial port when you press the[Enter]key(or when F2.8/2.9=3,input a signal)

F4.1/4.3=4,F4.8=0,F4.9=0

NO:	1
GROSS:	8.888kg
TARE:	0.000kg
NET:	8.888kg

F4.1/4.3=4,F4.8=1,F4.9=0

次数:	1
毛重:	8.888kg
皮重:	0.000kg
净重:	8.888kg

Among them,the row of NO:(次数:) will be output in a particular mode (4,5,6,7,9,11) after the completion of a process, then trigger auto-print.This column will not be output in other modes.

F4.1/4.3=4,F4.8=0,F4.9=1

UNIT:kg			
NO	GROSS	TARE	NET
	8.888	0.000	8.888
	8.888	0.000	8.888

F4.1/4.3=4,F4.8=1,F4.9=1

单位:kg			
次数	毛重	皮重	净重
	8.888	0.000	8.888
	8.888	0.000	8.888

Among them,the column of NO:(次数:) will be output in a particular mode (4,5,6,7,9,11) after the completion of a process, then trigger auto-print.Other modes default to null.The number of page-breaks for wide-line printing can be set in F4.10 according to the size of the paper.Notice to subtract 2 lines (for the title) when setting.

Appendix 5 Continuous Output 3

Data Frame																		
X	X	,	X	X	,	X	X	X	X	X	X	X	X	X	X	X	C	L
State1	separator		State2	separator		Weight							Unit		End			

State1

OL: Over Load

ST: Stable

US: Unstable

State 2

NT: Net

GS: Gross

Weight

Weight Contains 8 bit, include "+" / "-" sign bit, decimal point and space.

Unit

g: gram

kg: kilogram

kn: kilonewton

E.g. the terminal display stable gross weight "-1234.5". the serial port will transfer string as "= -1234.5".

S	T	,	G	S	,	-	1	2	3	4	.	5	k	g	CR	LF
Stable	Separator		Gross	Separator		Weight							Unit		End	

Appendix 6 Command mode

The command format of this instrument is in the ASCII code format

Read command:

R	E	A	D	<CR>	<LF>
---	---	---	---	------	------

Return information same as appendix 5.

Tare on command:

T	A	R	E		O	N	<CR>	<LF>
---	---	---	---	--	---	---	------	------

Success show YES<CR><LF>

Failure show NO?<CR><LF>

Tare off command:

T	A	R	E		O	F	F	<CR>	<LF>
---	---	---	---	--	---	---	---	------	------

Success show YES<CR><LF>

Failure show NO?<CR><LF>

Zero on command:

Z	E	R	O		O	N	<CR>	<LF>
---	---	---	---	--	---	---	------	------

Zero rang refer to F1.12

Success show YES<CR><LF>

Failure show NO?<CR><LF>

Appendix 7 Prompt or Error Messages

Number	Prompts	Explanations
1	[r-----]	Over capacity
2	[L-----]	Under zero
3	[Ad Err]	AD channel initialize failed
4	[EP Err]	EEPROM Readout error
5	[-EEE]	Power up zero failed for under negative zero range.
6	[EEE]	Power up zero failed for out of positive zero range.
7	[End]	Prompt to indicate zero/span calibration completed.
8	[Err 03]	Input weight value is too small when calibrating span via communication.
9	[Err 05]	Input weight value is too big when calibrating span via communication.
10	[Err 06]	The added load weight is too small when calibrating span via communication.
11	[Err 07]	The scale is in motion when calibration
12	[E_5CAL]	Prompt to empty scale when calibration
13	[LOAD]	Prompt to added load when calibration
14	[--∅--]	Invalid operation.
15	[--OF--]	The total quantity/weight overflow.

Appendix 8 Packing list

BC360L weighing Indicator Packing List

Number	Product	Model	Qty.	Note
1	Weighing Indicator	BC360L	1	
2	Manual	BC360L	1	
3	Certification Card	BC360L	1	
4	Power supply terminal	5.08-3P	1	
5	Load Cell Terminal	3.81-5P	1	
6	UART and/or DA terminal	3.81-8P	1	
7	Input/Output terminal	3.81-7P	1	
8				

Package: _____

Check: _____

Contact us:

All Rights Reserved