

DYNAMIC CHECKWEIGHER CW-30K

- Heavy load, for product weight up to 30kg, with accuracy $\pm 5g$;
- 10-inch screen, easy to operate;
- 100 different products storage;
- Widely used for checking weight of products in boxes, bags, barrel, etc.

Multiple industrial application



Food



Logistic



Automation
production line



30 kg
Maximum capacity

$\pm 5g$
Best accuracy

40 Pcs/min
Highest speed

Optional



Standard specification

Model	CW-30K
Maximum capacity	30kg
Scale division	1g
Best accuracy*	$\pm 5g$
Highest weighing speed*	30~40 pcs/min
Belt speed	22~34 m/min
Belt size	800x500mm
Weighing platform height *	750+100mm/-50mm
Belt material	PVC (black)
Structure of the material	Carbon steel, S304 for weighing platform
Alarm light	3-color signal light (Red, yellow, green)
Display size	10-inch color touch screen
Rejector lineup	Options: roller push type
Power	Single Phase AC-220V $\pm 10\%$, 50/60HZ, 275W
Operating temperature	0~40°C
IP grade	IP54/IP65 Optional

*Depend on the weight, size, and material of test object

Dimensions

Unit:mm

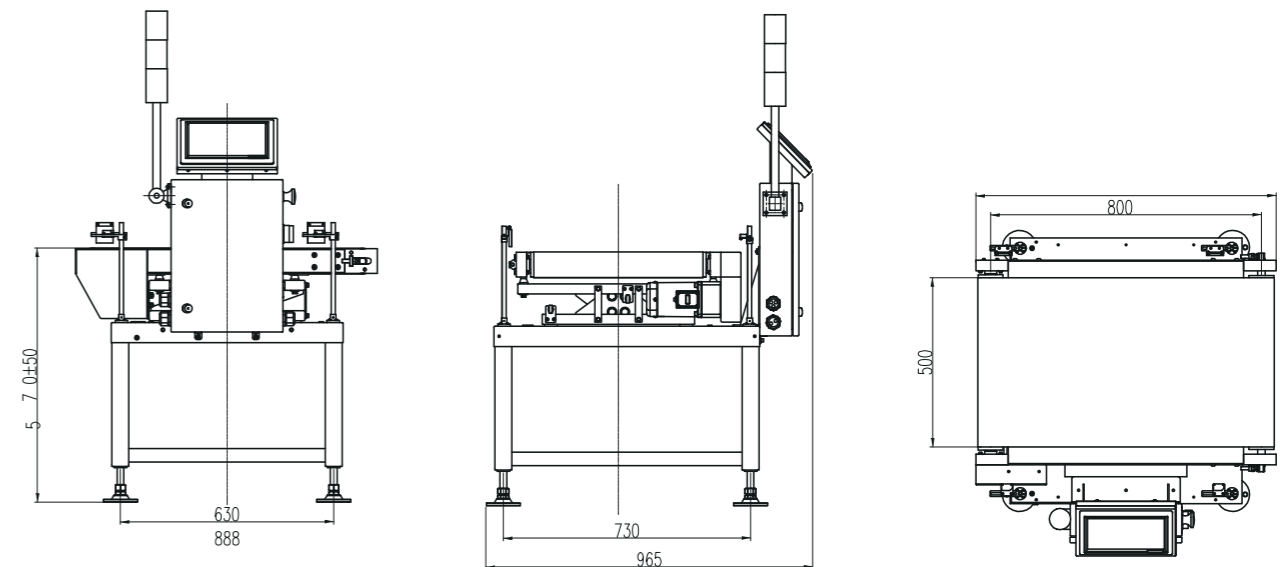

*Specification and dimension may be upgraded, please consult sales manager for the latest info.