

WEIGHT CHECK & SORTING MACHINE CW-6K

- Can be used for sorting up to 11 grades of weight;
- For raw food, bags, bottles, containers and so on;
- SS304 stainless steel, IP65;
- 10-inch touch screen;
- Can store over 1 million entries, data export by USB.

Multiple industrial application



6kg
Maximum capacity

±2g
Best accuracy

100 Pcs/min
Highest speed



Standard specification

Model	CW-6K
Maximum capacity	6kg
Scale division	0.5g
Best accuracy*	±2g
Highest weighing speed*	100 pcs/min
Belt speed	10~50 m/min
Belt size	500x400mm
Weighing platform height *	750+100mm/-50mm
Belt material	PU (blue/white)
Structure of the material	S304
Alarm light	3-color signal light (Red, yellow, green)
Display size	10-inch color touch screen
Rejector lineup	Options: swing type, push type
Power	Single Phase AC-220V±10%,50/60HZ,2500w
Operating temperature	0~40°C
IP grade	IP65

*Depend on the weight, size, and material of test object

Dimensions

Unit:mm

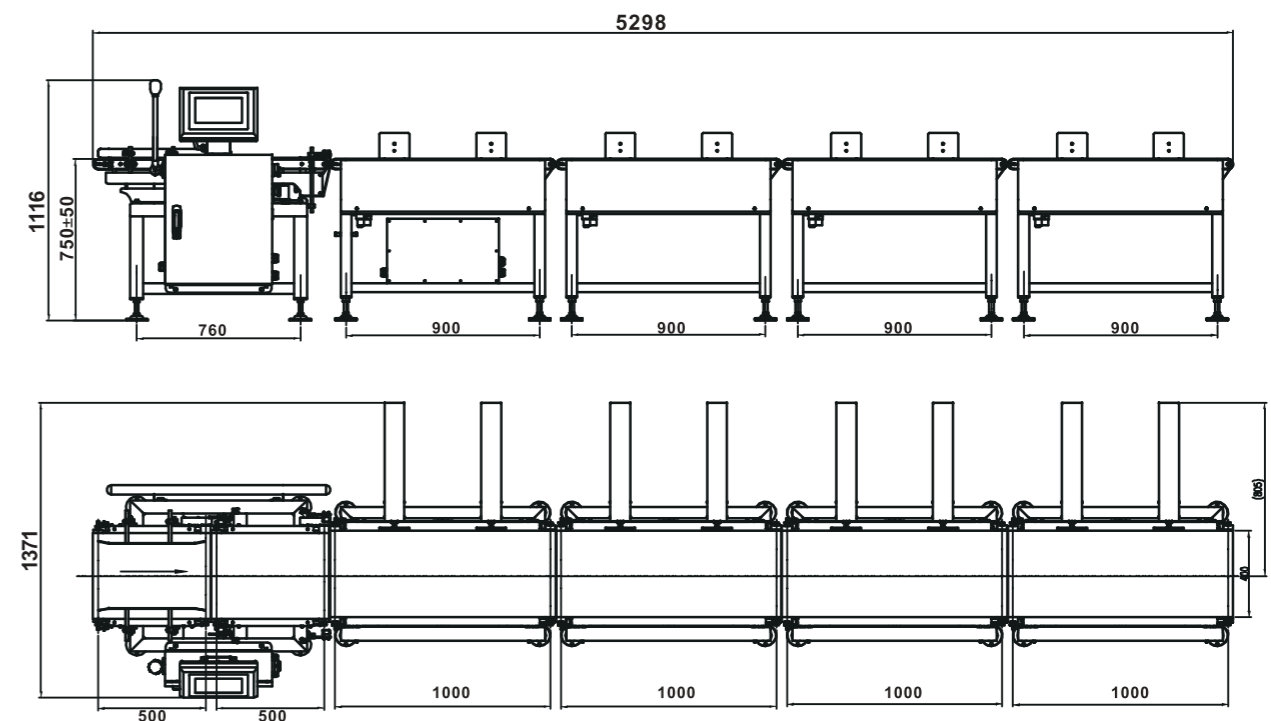

*Specification and dimension may be upgraded, please consult sales manager for the latest info.