

DUPLEX PACKING FILLER AF-10KII



0.5-10kg
Weighing range

±2~10g
Accuracy range

2400 Pcs/h
Top speed

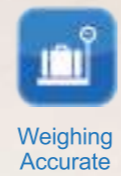
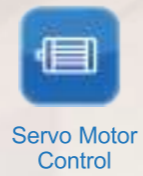
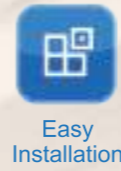
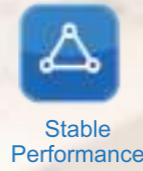

Features:

- **Granular material:** design for rice, millet, beans and other granular material;
- **Easy dismounting:** module design of measuring hopper for easy cleaning;
- **Parameter setting:** self-adjust function with target value set only;
- **Stable performance:** servo motor controls feeding process;
- **Fast and accurate:** weighing range is 0.5-10kg, Speed can reach 2400 pcs/h, and accuracy range ± 2~10g.

Optional:



User-friendly interface design, vivid display, easy to operate.



Specification	
Model	PaxGO AF-10KII
Weighing range	0.5~10Kg
Division	1g
Accuracy range*	±2~10g
Top speed*	2400 pcs/h
Volume	18L x 2
Feeding method	Servo motor + feeding vibrator , pneumatic discharging
Material	SS304, carbon steel
I/O	8 output(5V),8 input(24V)
Communication	RS485, Modbus TCP/IP
Pneumatic	0.4~0.6MPa
Power	Single Phase AC-220V ±10%,50/60HZ,1KW
Working environment	0~40°C , 90%R.H condensation is not allowed

*Accuracy and speed depends on the material characteristics and packing weight.

Structure & Dimension

Unit: mm

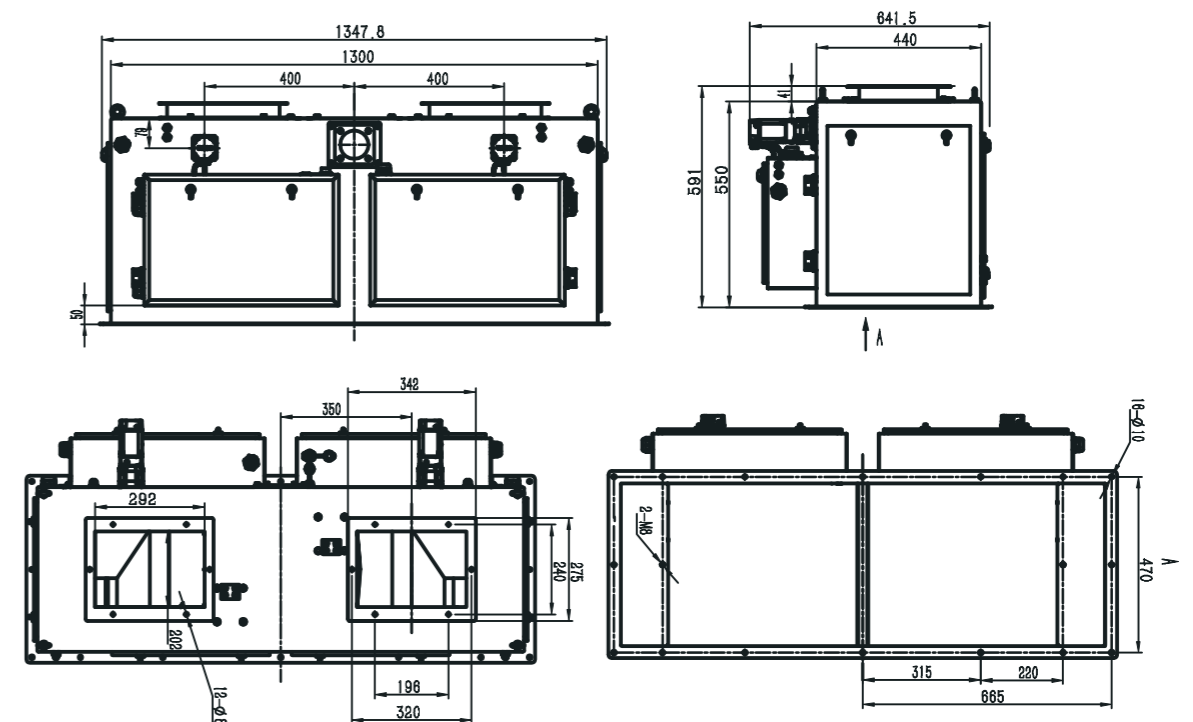

*Specification and dimension may be upgraded, please consult sales manager for the latest info.