

DUPLEX PACKING FILLER AF-25K II



5-25kg
Weighing range

±5~15g
Accuracy range

2200 Pcs/h
Top speed

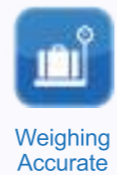
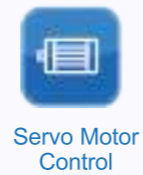
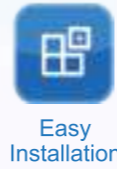
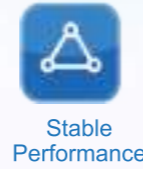

Features:

- **Granular material:** design for plastic particle, granular fertilizer, feeds and other granular material;
- **Easy dismounting:** module design of measuring hopper for easy cleaning;
- **Parameter setting:** self-adjust function with target value set only;
- **Stable performance:** servo motor controls feeding process;
- **Fast and accurate:** weighing range is 5-25kg, Speed can reach 2200 pcs/h, and accuracy range $\pm 5\sim 15g$.



Optional:

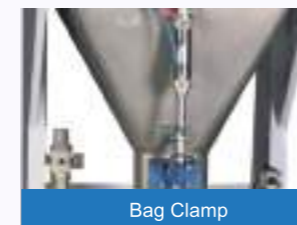

- SS304 stainless steel.



Specification	
Model	PaxGO AF-25K II
Weighing range	5~25Kg
Division	1g
Accuracy range*	$\pm 5\sim 15g$
Top speed*	2200pcs/h
Volume	55L x 2
Feeding method	Feeding control by servo, pneumatic discharging
Material	SS304, carbon steel
I/O	8 output(5V), 8 input(24V)
Communication	RS485, Modbus TCP/IP
Pneumatic	0.4~0.6MPa
Power	Single Phase AC-220V $\pm 10\%$, 50/60HZ, 2KW
Working environment	0~40°C, 90%R.H condensation is not allowed

*Accuracy and speed depends on the material characteristics and packing weight.

Structure & Dimension

Unit: mm

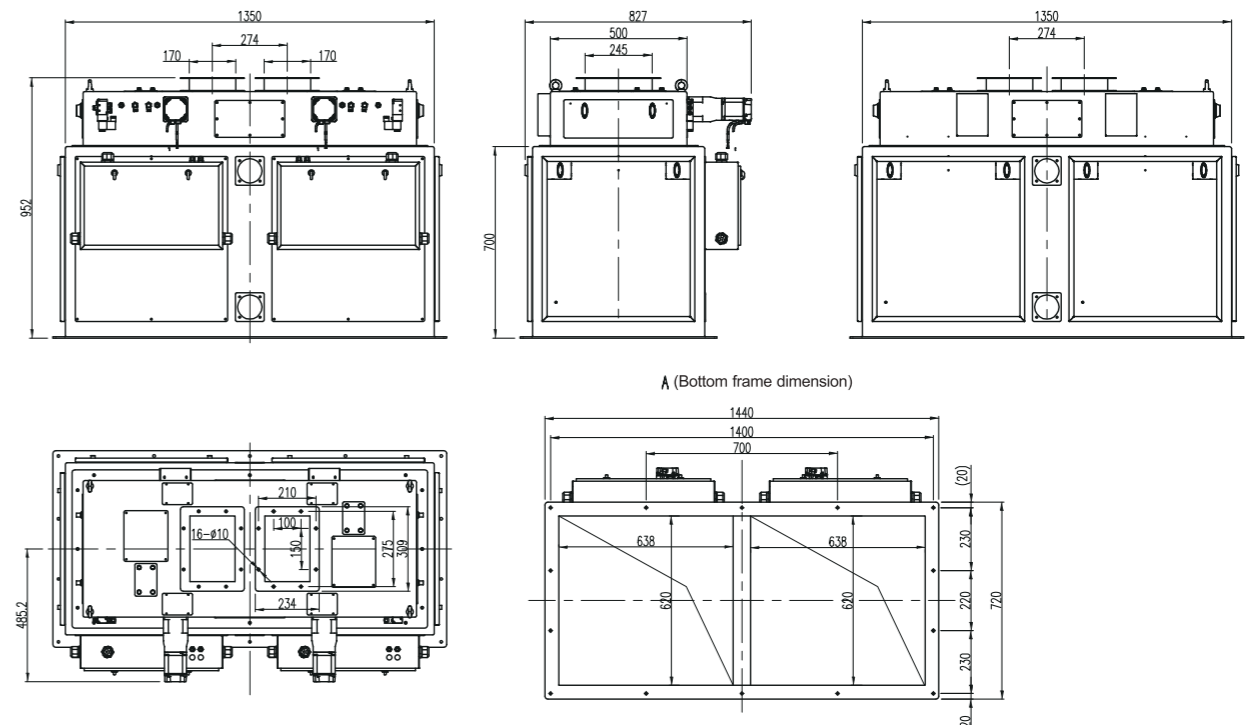

*Specification and dimension may be upgraded, please consult sales manager for the latest info.